

7

Units:mm

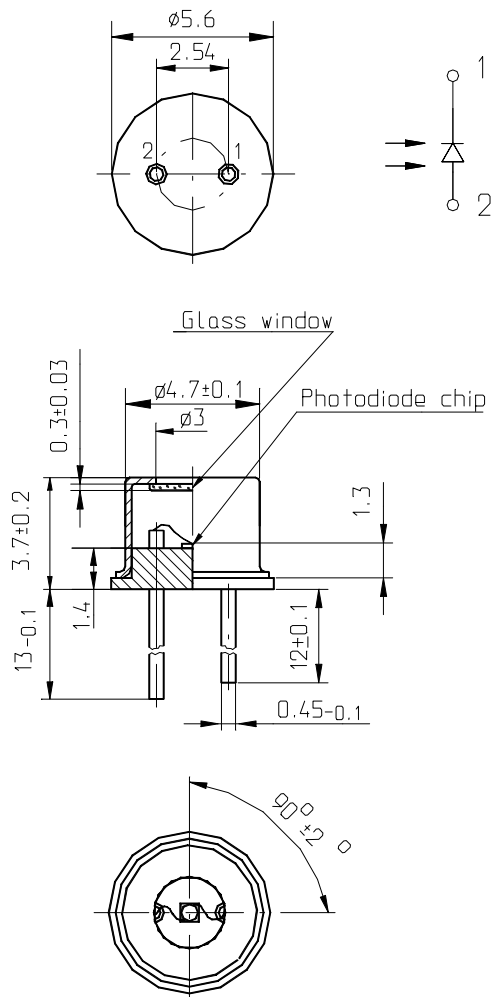

8

Units:mm

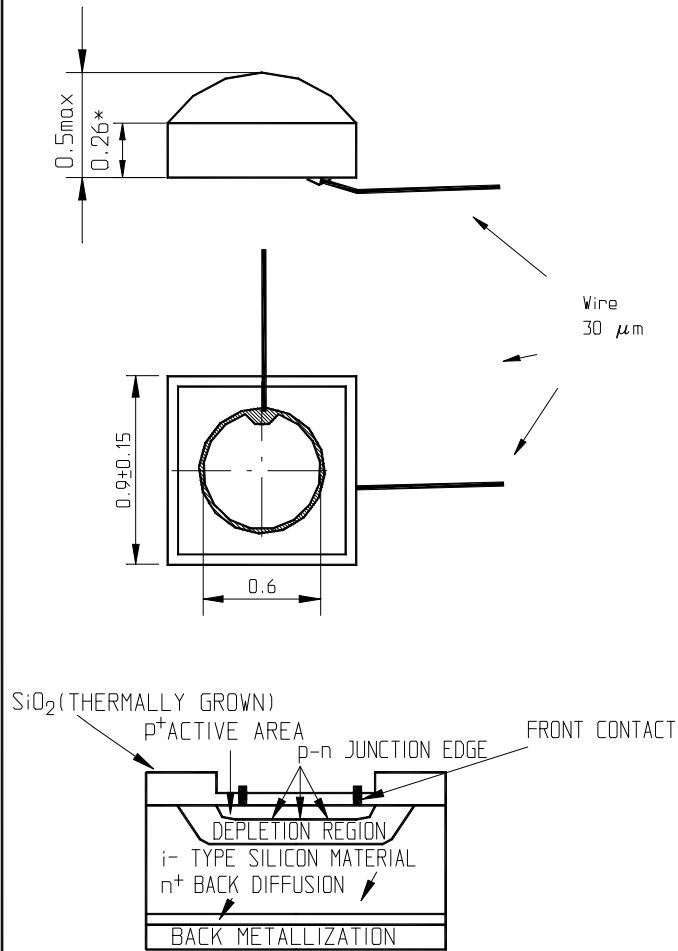

9

Units:mm

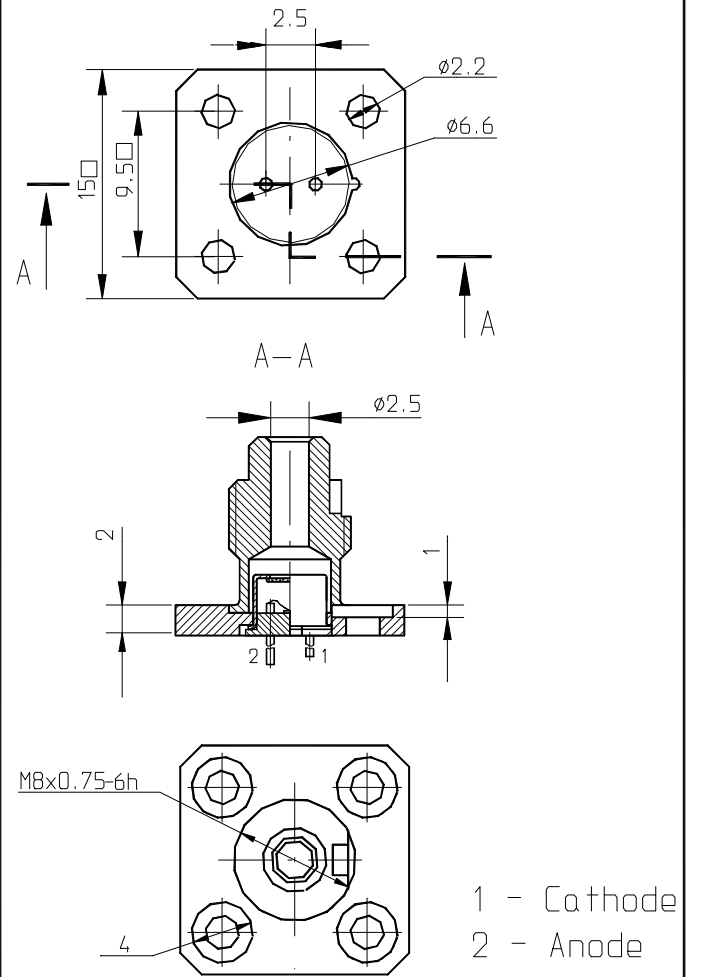

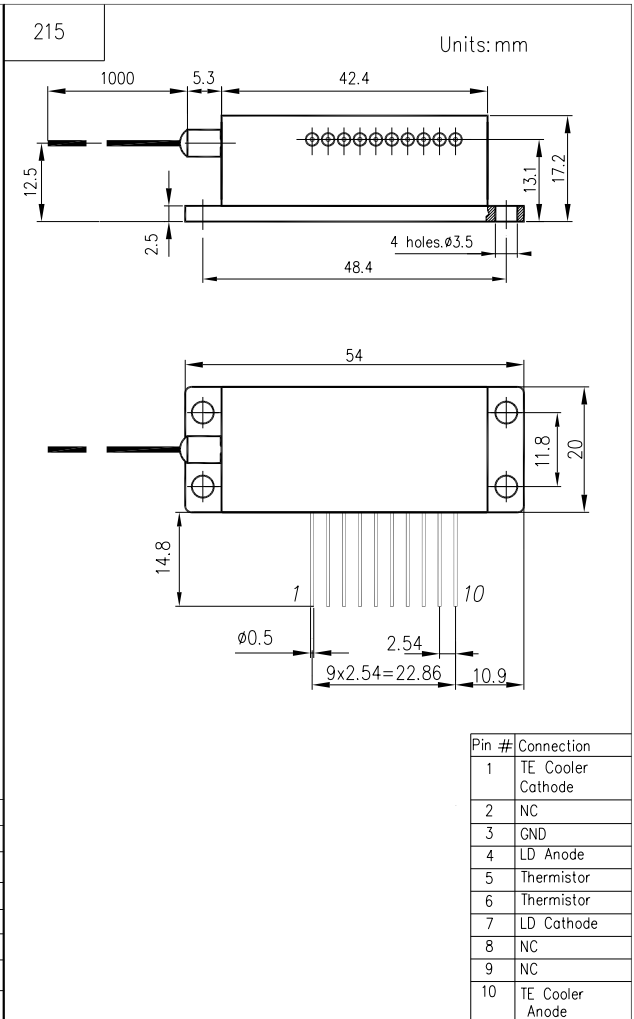
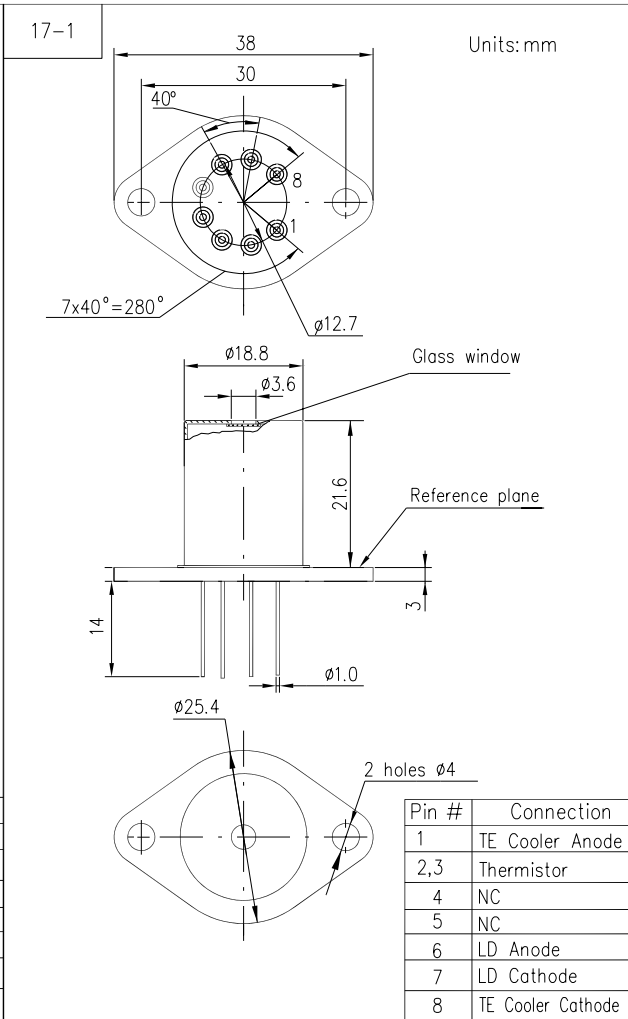
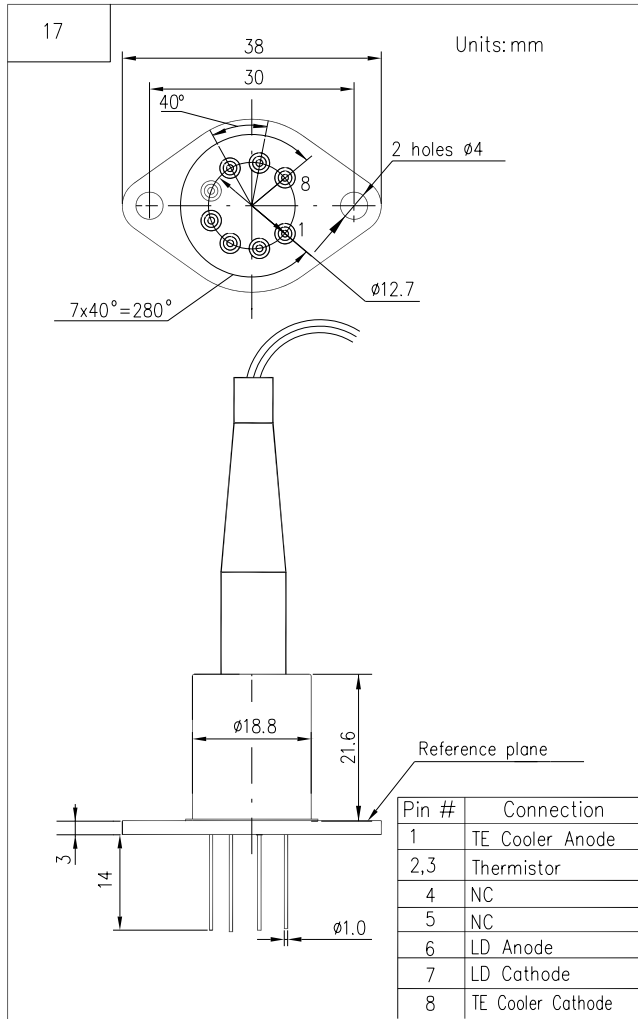

201

Units:mm

Flat package

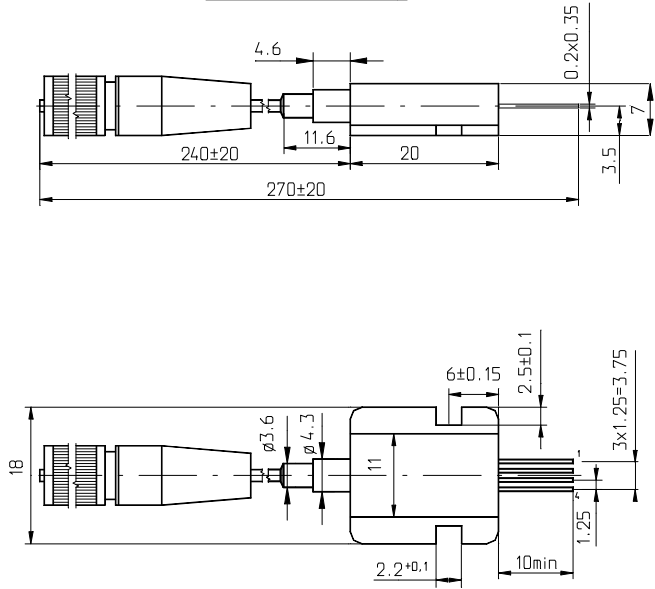

Pin #	Connections
1	LD or SLD Anode, GND
2	LD or SLD Cathode
3	Photodiode Cathode
4	Photodiode Anode

202-1

Units:mm

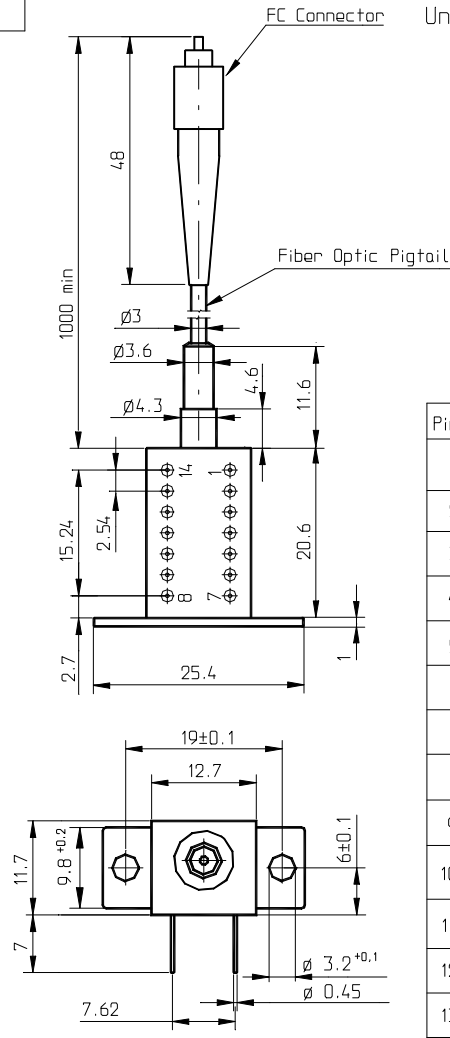

Pin#	Connections
1	TE Cooler Anode
2	NC
3	NC
4	NC
5	GND
6	NC
7	PD Cathode
8	PD Anode
9	SLD Cathode
10	SLD Anode
11	Thermistor
12	Thermistor
13	NC
14	TE Cooler Cathode

202

Units:mm

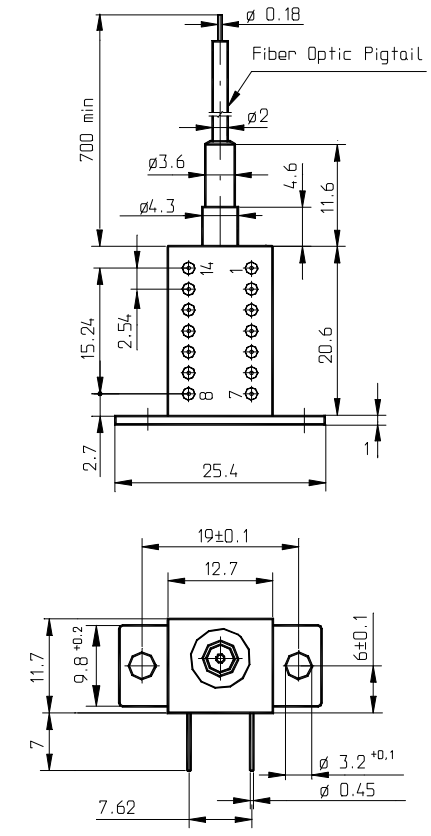

Pin#	Connections
1	TE Cooler Anode
2	NC
3	NC
4	NC
5	GND
6	NC
7	PD Cathode
8	PD Anode
9	SLD Cathode
10	SLD Anode
11	Thermistor
12	Thermistor
13	NC
14	TE Cooler Cathode

203

Units:mm

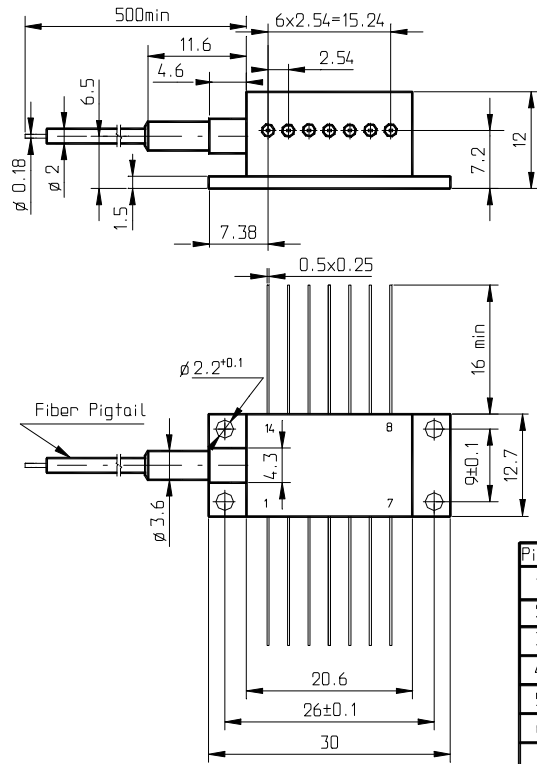

Pin#	Connections
1	TEC Cathode
2	TEC Anode
3	Termister
4	Termister
5	Case Ground
6	SLD Anode
7	SLD Cathode
8	PD Cathode
9	PD Anode
10	NC
11	NC
12	NC
13	NC
14	NC

203-1

Units:mm

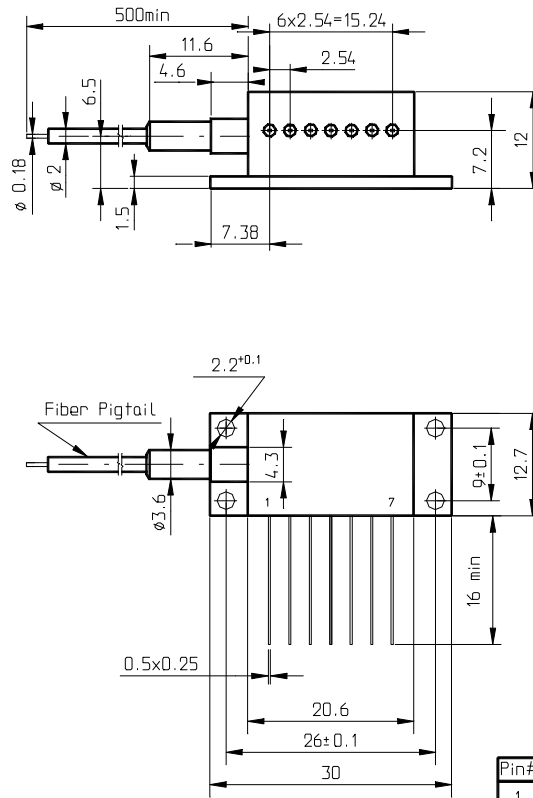

Pin#	Connections
1	TEC Cathode
2	TEC Anode
3	Thermistor
4	Thermistor
5	Case Ground
6	SLD Anode
7	SLD Cathode

203-2

Units:mm

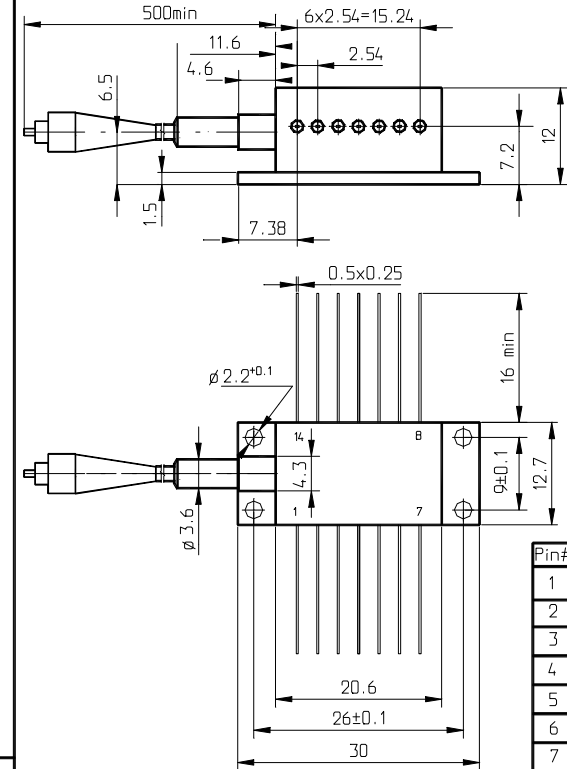

Pin#	Connections
1	TEC Cathode
2	TEC Anode
3	Termistor
4	Termistor
5	Case Ground
6	SLD Anode
7	SLD Cathode
8	PD Cathode
9	PD Anode
10	NC
11	NC
12	NC
13	NC
14	NC

204

Units:mm

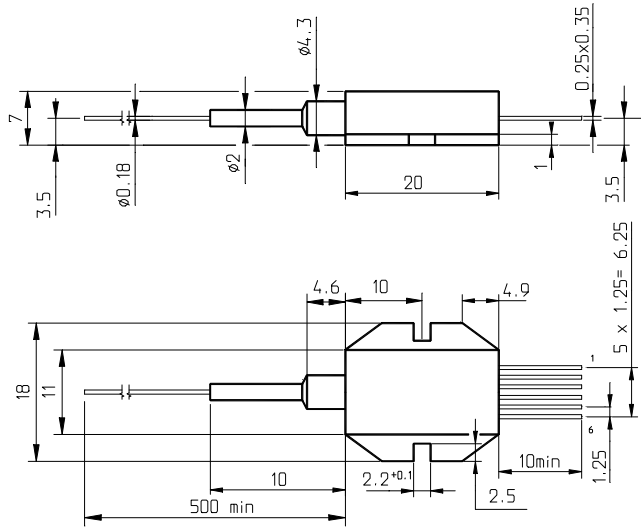

Pin#	Connections
1	SLD Anode
2	SLD Cathode
3	PD Cathode
4	PD Anode
5	Thermistor
6	Thermistor

204-1

Units:mm

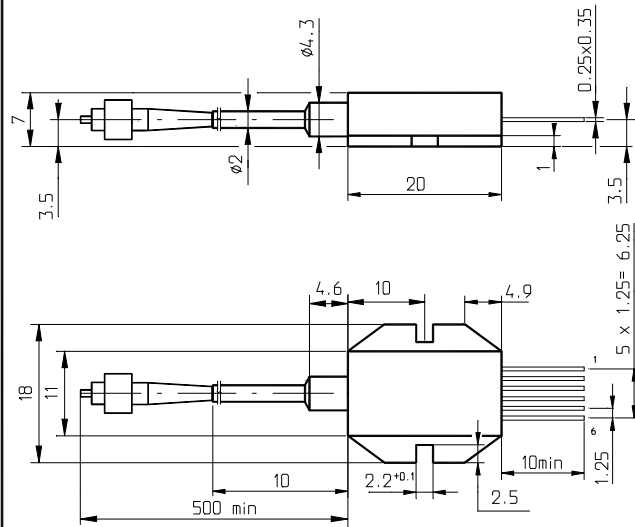

Pin#	Connections
1	SLD Anode
2	SLD Cathode
3	PD Cathode
4	PD Anode
5	Thermistor
6	Thermistor

205

Units:mm

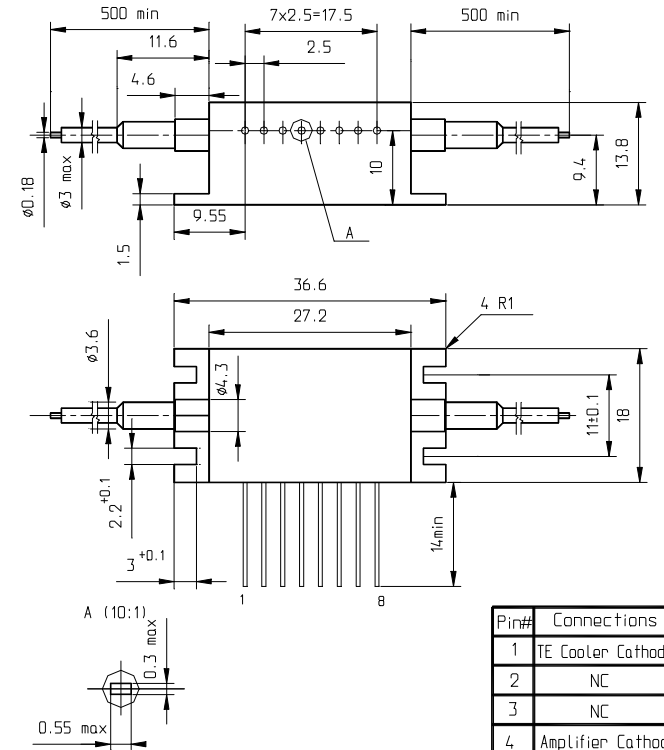

Pin#	Connections
1	TE Cooler Cathode
2	NC
3	NC
4	Amplifier Cathode
5	Amplifier Anode
6	Thermistor
7	Thermistor
8	TE Cooler Anode

206

Units:mm

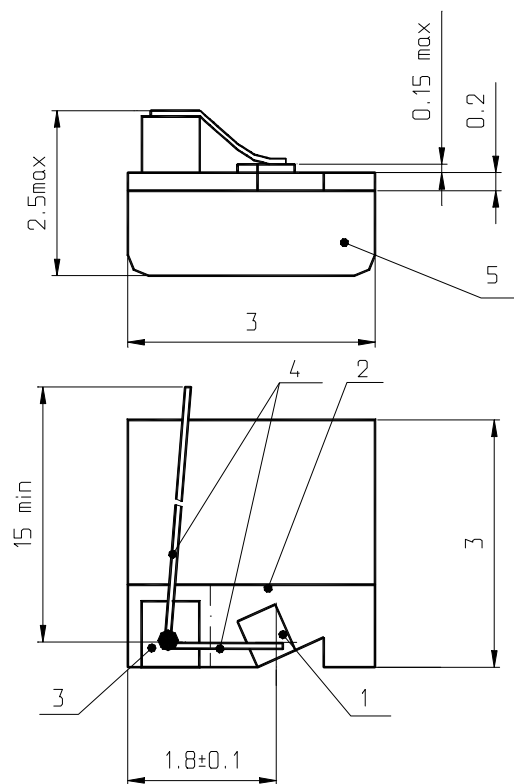

- 1- SLD chip  
2- Metal heatsink  
3- Ceramic  
4- Wire contact  
5- Cu heatsink

207

Units:mm

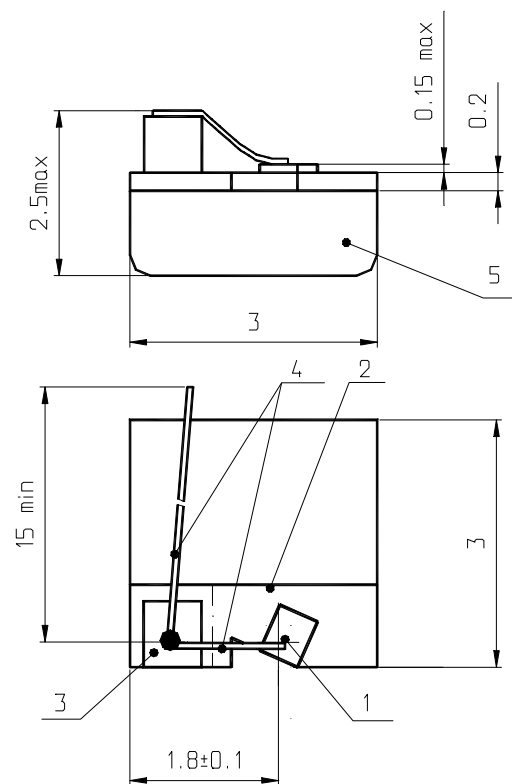

- 1- SLD chip  
2- Metal heatsink  
3- Ceramic  
4- Wire contact  
5- Cu heatsink

208

Units:mm

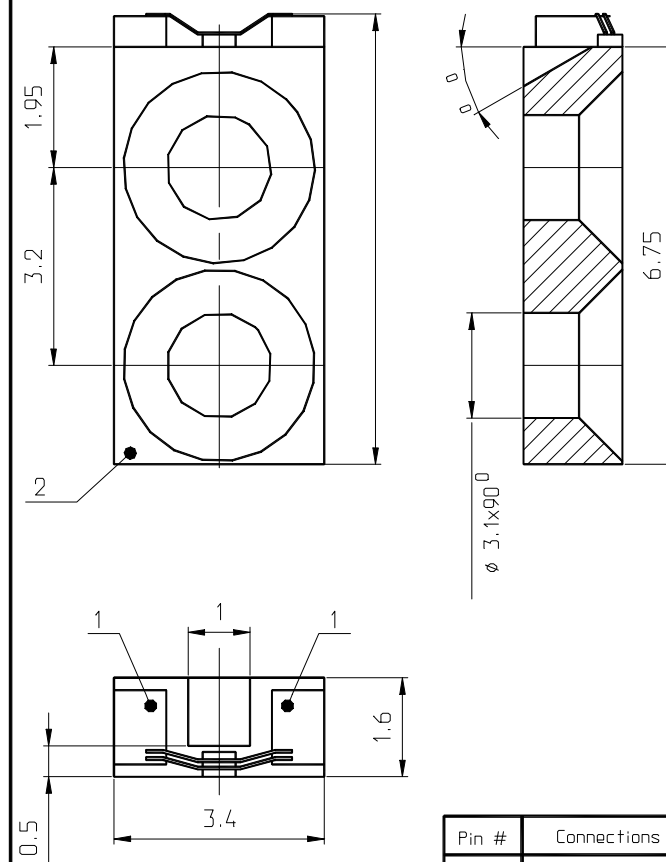

Pin #	Connections
1	LD Cathode
2	LD Anode, GND



210

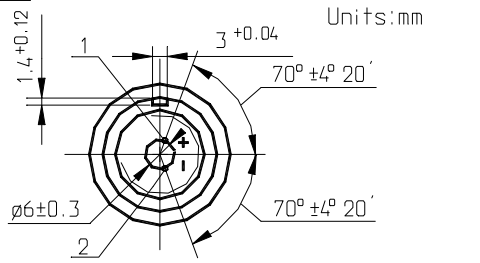

Units:mm

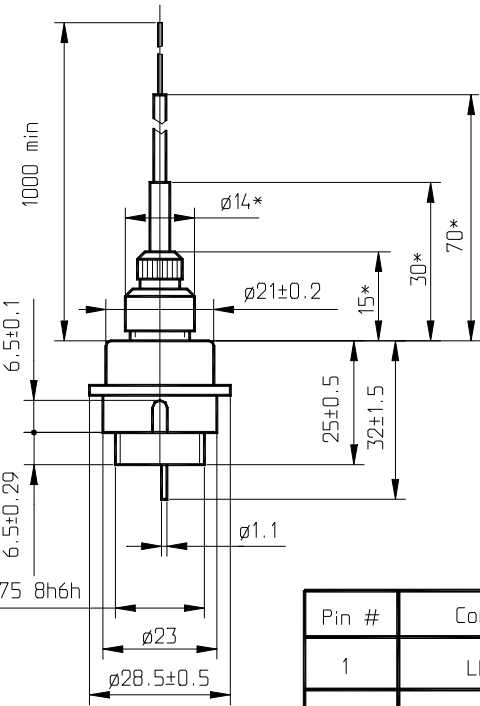

Pin #	Connections
1	LD Anode
2	LD Cathode

211

Units:mm

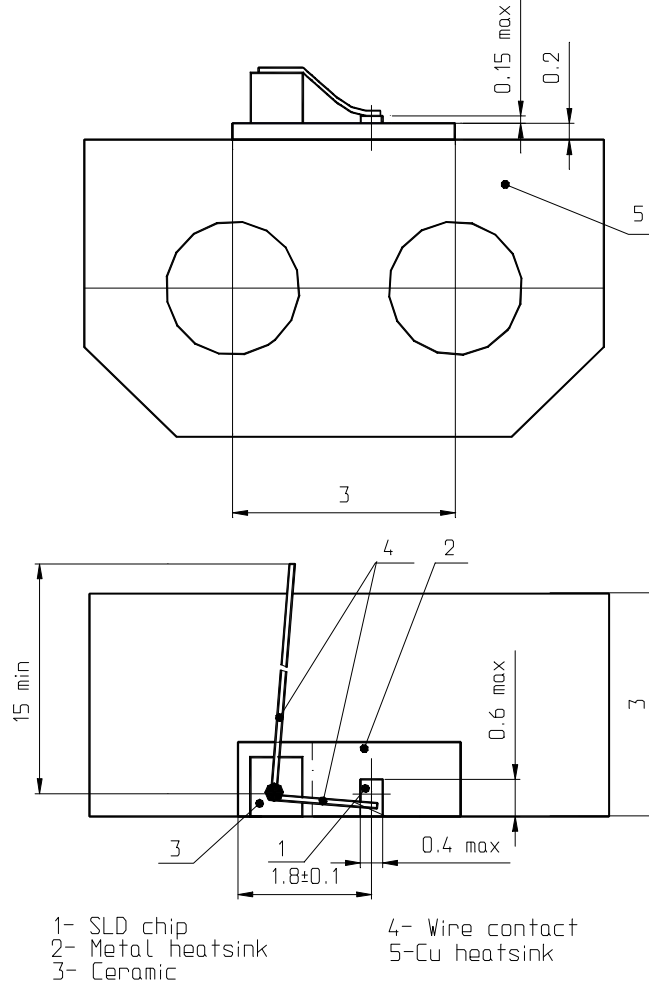

212

Units:mm

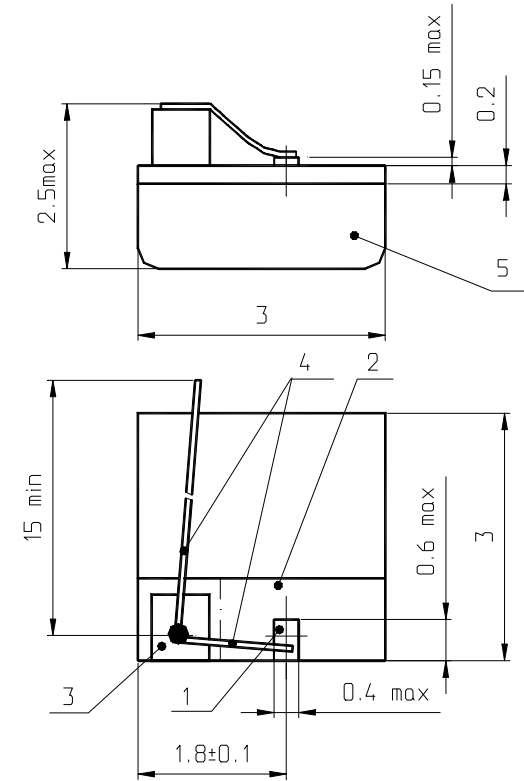

- 1- SLD chip
- 2- Metal heatsink
- 3- Ceramic
- 4- Wire contact
- 5-Cu heatsink

301

Units:mm

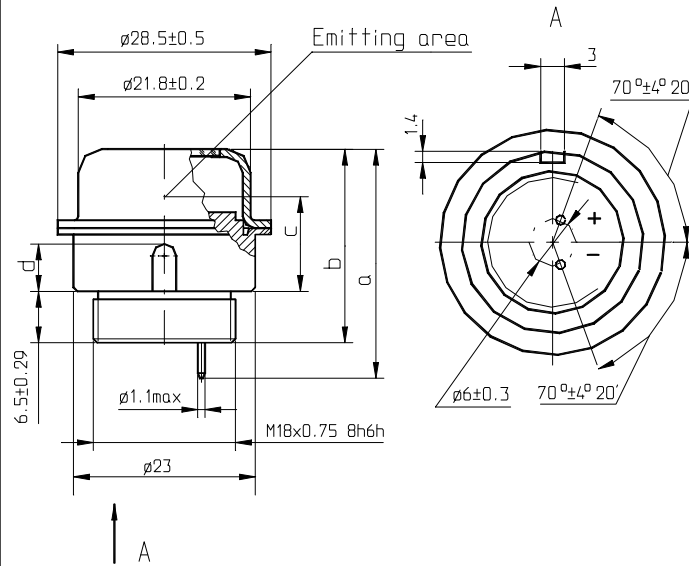

	Size, mm			
	a	b	c	d
L-2				
L-3				
L-4				
L-5	32±1.5	25±0.5	13.2±0.2	6.5±0.1
L-6				
L-10				
L-11				
L-9	36.5	29.5±0.5	19±0.1	8±0.1
L-13				

302

Units:mm

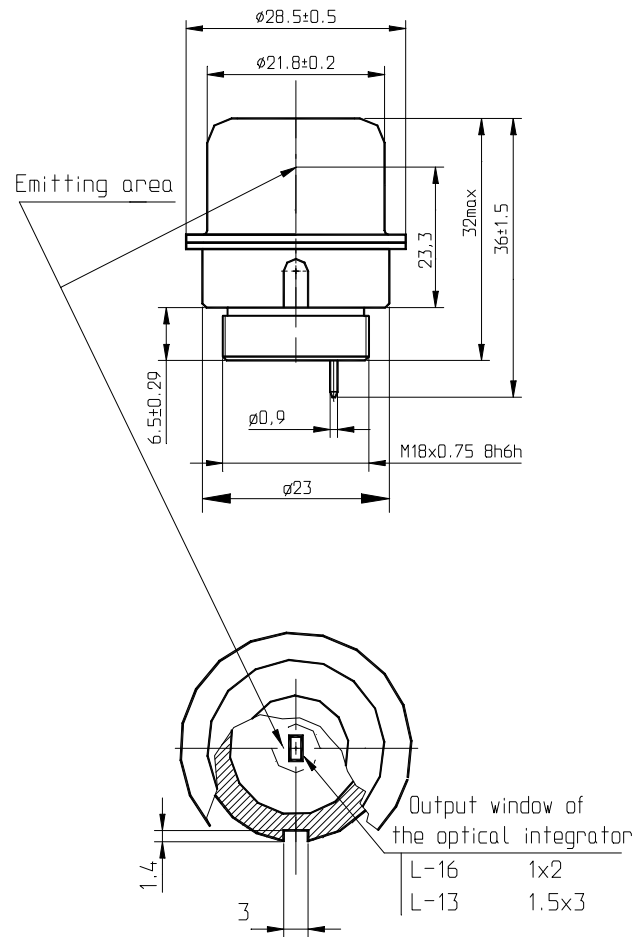

303

Units:mm

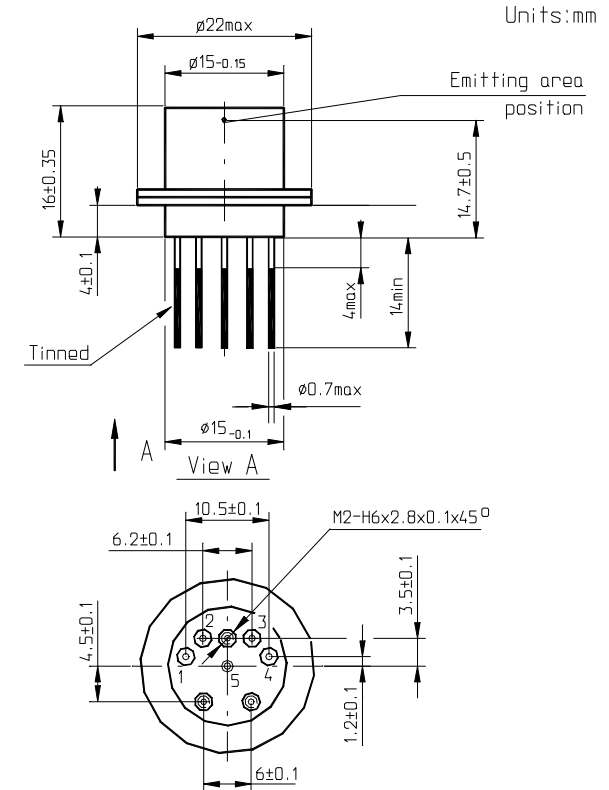

Pin #	L-12
1	Supply voltage (ANODE)
2	Sync pulse
3	Drive
4	To driving current limiting resistor
5	Supply voltage (CATHODE)